



HAMRICK

600D-S DROP PACKER



Round or Non-Round
Containers



30+
Cycles Per Minute



High
Production Volume



HAMRICK

600D-S DROP PACKER

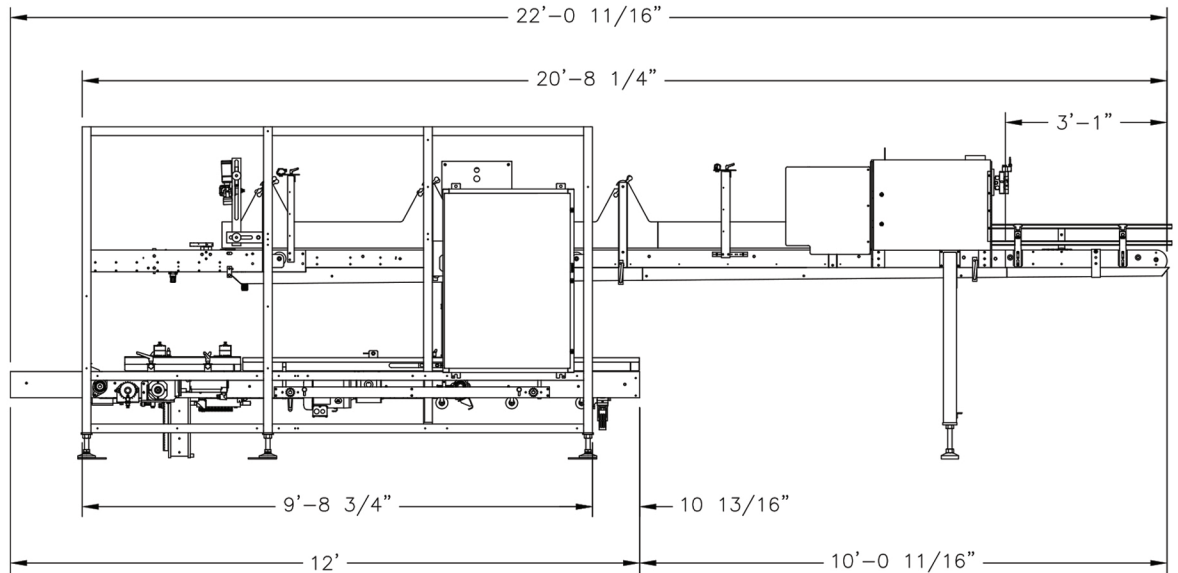
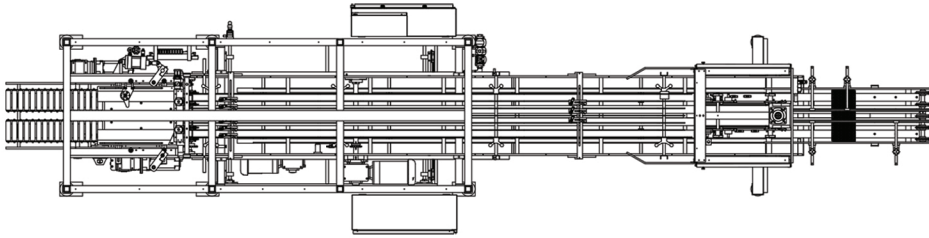

Machine Specifications

- One set of change parts included
- Premium controls package w/ Allen-Bradley CompactLogix PLC, PanelView Plus HMI, and PowerFlex 525 drives
- Servo lane divider, servo (rack & pinion) style case lift, and servo case indexing included
- Upgraded tubular steel frame (mild or stainless) with fully-enclosed pack area
- No-tool quick change points including hand crank adjustments for lane divider, case infeed rails, and overhead brake

Performance

- Individual case rates of up to 35+ cases per minute on RSC, HSC, tablock, trays, or re-shipper cases
- Ideal for undersized cases, machine can run speeds of 60+ cases per minute on two or three case per cycle operation
- Intralox chain minimizes transfer points and allows for split-speed product conveyor which assists in removing back-pressure and bounce back when running higher cycle rates
- Able to orient difficult or wide-side leading products using timing screw assemblies

One (1) Year Warranty and 100% Money Back Guarantee Always Included