



HAMRICK

CS50 HOT MELT TWIN CASE SEALER



50
Cases Per Minute

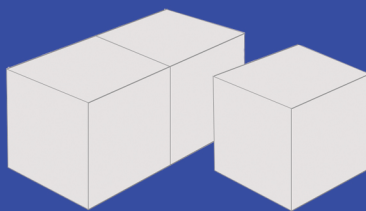

Double or Single
Case Input



Medium to High
Production Volume



HAMRICK

CS50 HOT MELT TWIN CASE SEALER

CONTROL STATION, GLUE UNIT
AND ELECTRICAL PANEL
MOUNTED ON SAME SIDE OF
MACHINE.

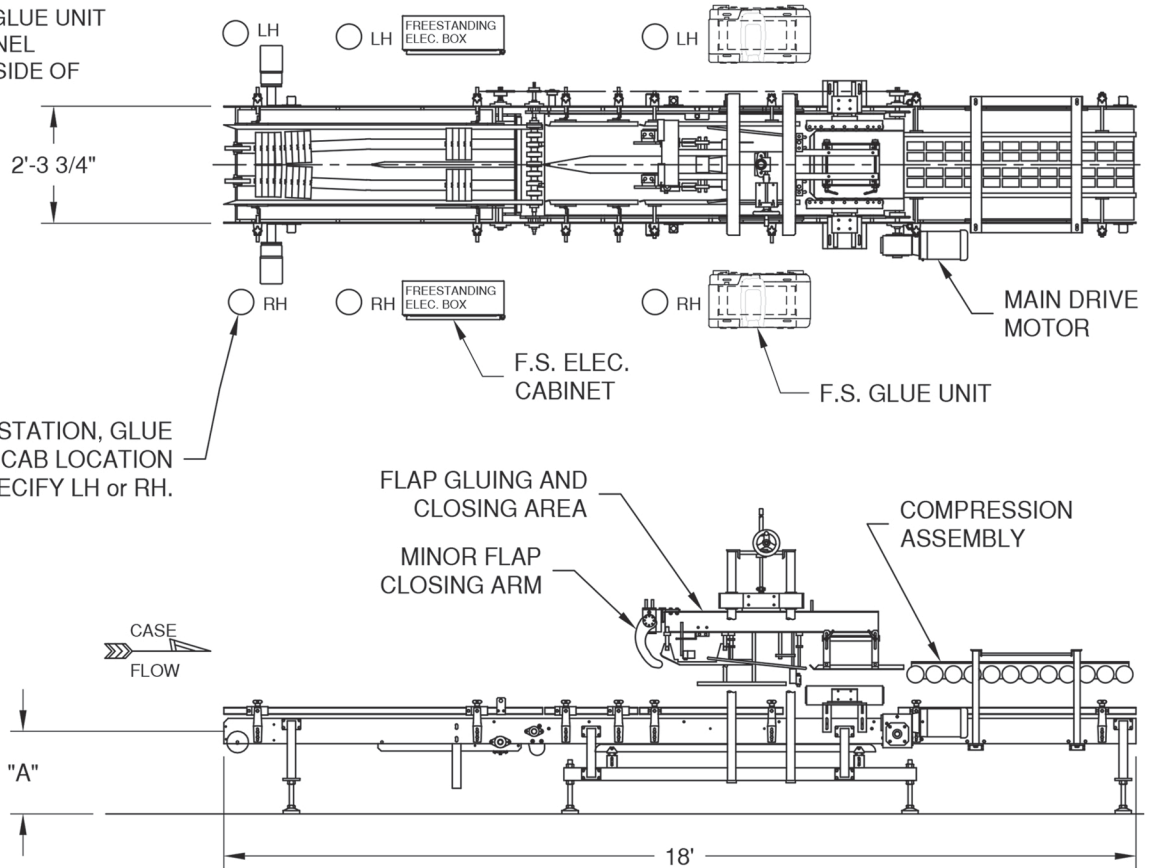

Unit Specifications:

Quick changeover from twin to single case output

Variable speed drive motor

Polished stainless steel exterior covers

Nordson Pro Blue Series hot melt glue system with anti-drip nozzles

Steel-It corrosion resistant paint

Allen-Bradley PLC controller

Upgrades Available:

3-Tier flashing light tree for interrupted cycles

Additional E-stop

Stainless steel construction with NEMA 4x electrical

Additional glue nozzle for spot-gluing of cases

Upcharge to non-standard voltage

One (1) Year Warranty and 100% Money Back Guarantee Always Included